

# Intelligent VoIP Gateway

# ★ IP1200C

**The Bridge Between IP Networks and the PSTN**

In addition to traditional voice networks, IP networks have turned to be a must in business communication systems. The Internet brings many benefits for enterprises like efficiency and cost-saving. Now empowered by IP1200C VoIP Gateway, the converged voice and data network, which is built over your existing infrastructure, will make your business more competitive and have more advantages.

## High Performance Gateway



## The Best VoIP Solution

for Cyber Café Business

- ▶ **Reduce Communication Costs** Adopting the advanced technology of packet-switching telephony, IP1200C VoIP Gateway delivers calls over the Internet to significantly lower your costs on long-distance and international calls.
- ▶ **Easy and Seamless Connections** Simply distribute one IP1200C at your site then you have built a global communication channel to regular phones worldwide. You could stack up as many devices as you need at a site.
- ▶ **Convenient Device-to-Phone Service** IP1200C offers value-added Device-to-Phone Operation Mode allowing you to place Internet calls directly to any regular phone in the world. The Device-to-Phone service is provided with low calling rates.
- ▶ **Online CDR** Using the specially designed DSG My Account Center web page, users can view their calling detail records immediately after they hang up the phone.
- ▶ **User Friendly Interface** IP1200C provides 4 voice ports supporting FXS. You can connect telephone sets directly to the ports.
- ▶ **Clear Voice Quality** Incorporating the standard-based CODECs, intellectual silence compressions, VAD and echo cancellation technologies, IP1200C offers high-quality voice communications.
- ▶ **Password Authentications** IP1200C features password protection scheme for every connection to IP1200C configurations.
- ▶ **Powerful IP1200C Management System** It provides Cyber Café's administrators and operators several tools to manage the calling business with ease.

# IP1200C Embedded VoIP Gateway

## Features List

- Easy to expand. No capacity limit at one site.
- Provide 4 voice ports.
- Support DHCP, pseudo IP address and real IP address.
- Support NAT and allow voice traffic to go through firewall.
- Every port has an ID Number.
- Support FXS interface for connection to the CO trunk side of a PBX or analog phones.
- Convenient Device-to-Phone Mode offering low calling rates for Internet calls directly to worldwide regular phones.
- Allow remote management using Telnet.
- Offer echo cancellation, busy tone detection and VAD (voice activity detection).
- Provide standard-based CODEC offering clear voice quality.
- On-line query each port's Device ID balance.
- Check calls history and the last transaction record on the DSG **My Account Center** web page.
- Free on-line software upgrades.

## IP1200C Management System

DSG IP1200C Management system provides real-time Call Monitoring, Port Status, Summary Report, Parameter Setup, Register ID, Change Password, Setup Rate Table, ID List, and many other functions, enabling IP1200C master to manage the Cyber Café calling business with ease and efficiency.



## IP1200C Network Diagram

As a VoIP gateway, IP1200C provides a seamless connection between TCP/IP networks and PSTN. DSG Global ITSP Network empowers IP1200C the Internet telephony feature allowing users to call any regular phone in the world with low calling rates.

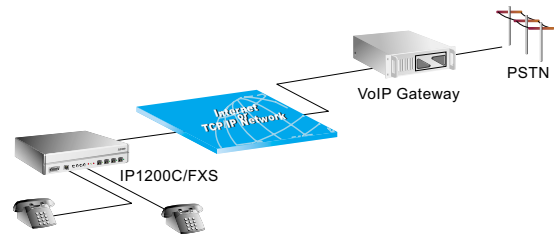

Voice and Data  
Convergence

## Specifications:

- Voice Compressions: G.723.1 standard
- LAN Port: Ethernet, 10BaseT, RJ45
- Voice Ports: 4-port module
- Voice Port Interface: FXS, RJ11
- COM Port: RS232, Baud Rate: 9600 bps
- Internet Protocols: TCP/IP, DHCP, Telnet
- Power Input: DC 5V/12V
- Temperature: 0°C ~ 50°C (32°F ~ 122°F)
- Humidity: 10% ~ 90% (Non-condensing)
- Internal RAM: 8MB
- LED Indicators: Voice ports status, 3 system active indicators
- Buttons: Default, Security, S1 and S2 buttons
- Dimensions: 315 mm x 198mm x 60mm
- Weight: About 2300 g

## Installation

The following diagram illustrates the connections of IP1200C.

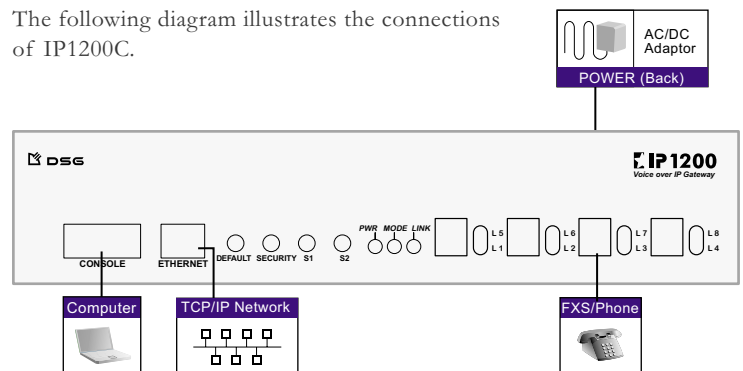

- Note:**
- \* DSG provides ITSP (Internet Telephony Service Provider) Services. With a valid account, subscribers can place Internet calls directly from IP1200C to any regular phone in the world.
  - \* Accessing DSG My Account Center web page requires authorized password of each port's Device ID.
  - \* Models of 8 voice ports are optional.
  - \* Specifications are subject to change without notice.

### Corporate Headquarters

7F, 222 Cheng Teh Road, Sec. 4,  
Taipei, Taiwan 111  
Tel :886-2-88615558  
Fax :886-2-88615557  
E-Mail :sales@dsg.com.tw

### DSG Technology USA

20265 Valley Blvd., # N  
Walnut, CA 91789  
Tel :1-909-5958908  
Fax:1-909-5955508  
E-Mail:sales\_na@dsgtechnology.com

### DSG Technology Shanghai

Tel:86-21-62708280 / 86-21-62708281  
Fax:86-21-62708338

### DSG Technology Qingdao

Tel:86-532-5796316 / 86-532-5796235  
Fax:86-532-5796326

 **DSG TECHNOLOGY**  
www.dsgtechnology.com